

8Ygyb\c: dfcXi n] Xc: dcf: j Yfg -c: UWUX..a] WZ: dfc] V] Xc: i gc: WcaYfWj U'

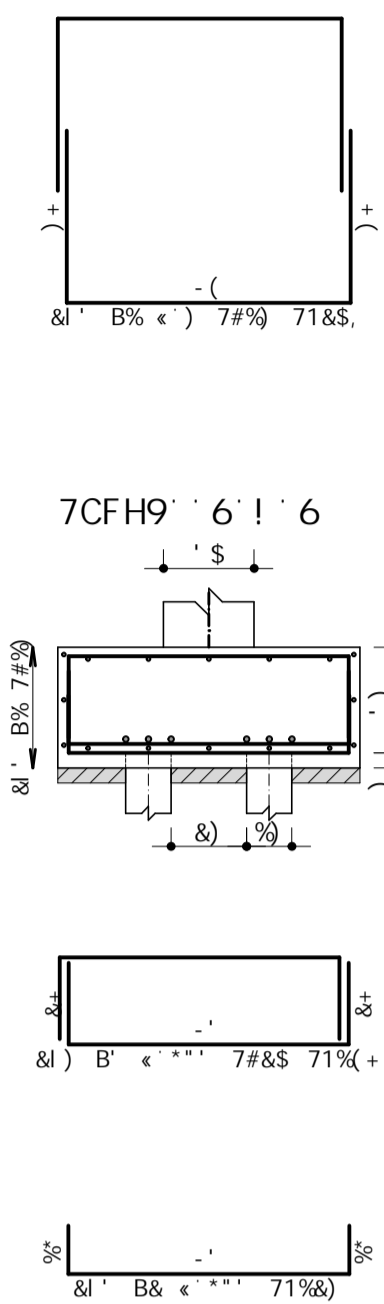

8Ygyb\c: dfcXi n] Xc: dcf: j Yfg -c: UWUX..a] WZ: dfc] V] Xc: i gc: WcaYfWj U'

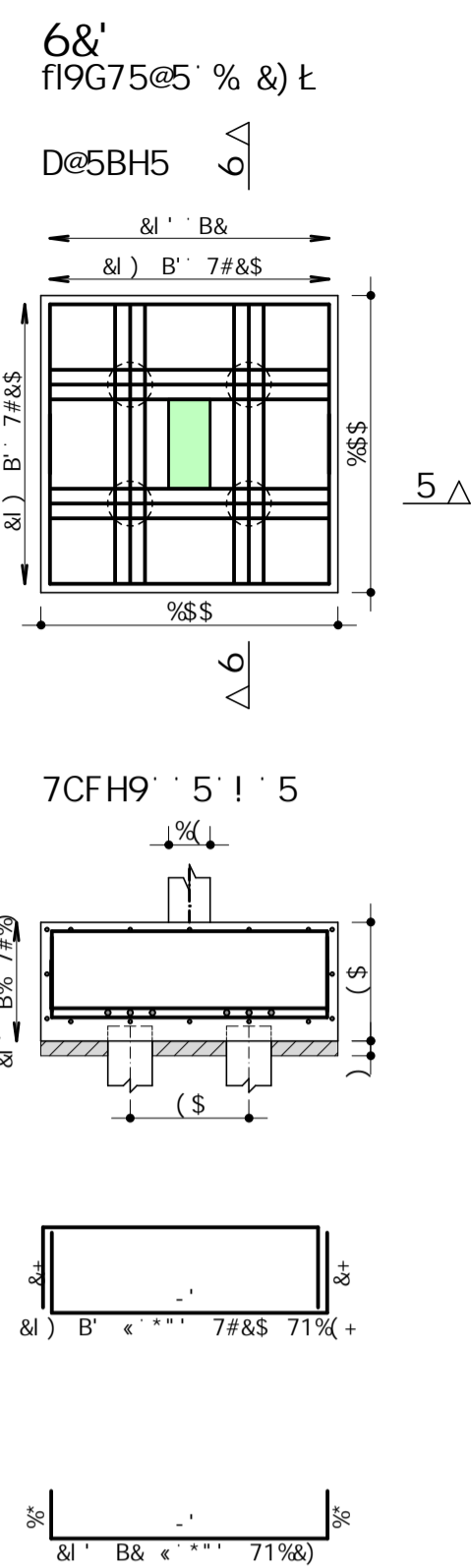
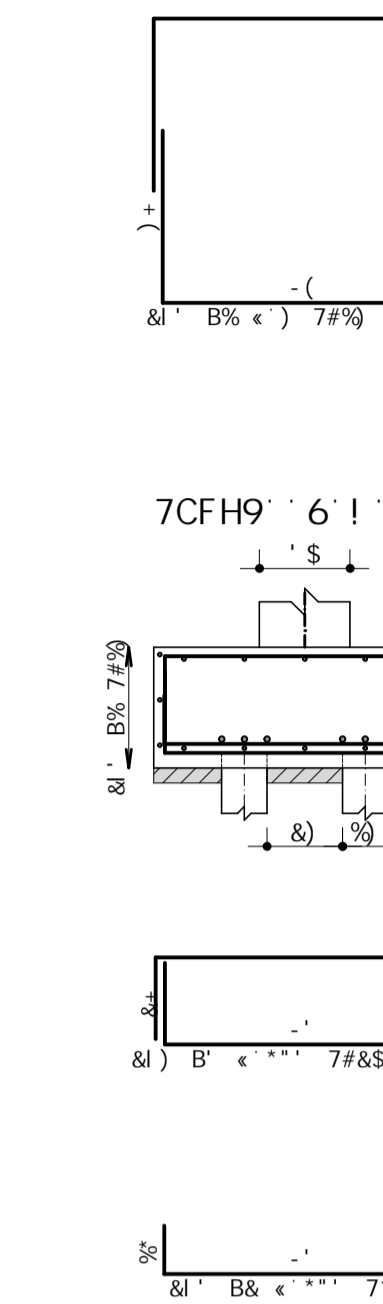
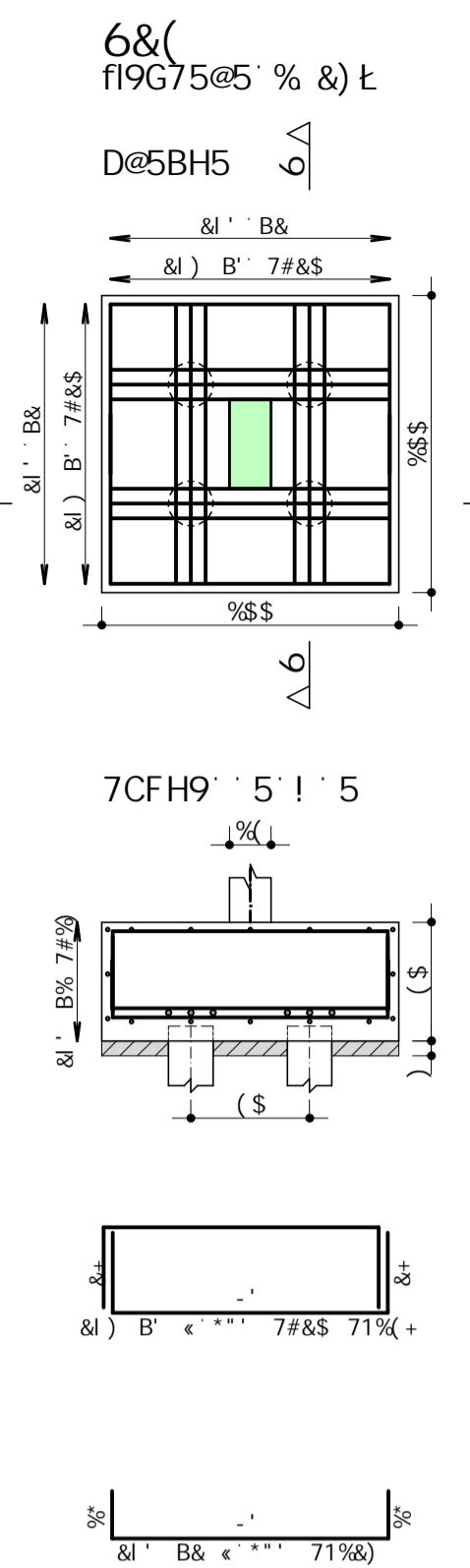

5uC	DCG	6=H	EI 5BH	7CADF=A9BHC
		aa		I B=H HCH5@ V&
6&				
	\$5	%		&S
	\$5	&		%&
	\$5			%&
6&(
	\$5	%		&S
	\$5	&		%&
	\$5			%&

F9GI AC 89 5uC			
5uC	6=H	7CADF	D9GC
	aa	a	[Z
	\$5	&	
DYgc: HchU		\$5 1	
DYgc: HchU		\$5 1	&& [Z

FYj	8UhU	5i hcf	5ggi bhc
\$S	& #S' #&S&&	Gi GSBM 6CB-BI	756F5@
7CB7F9HC ZVL 1 &) ADU 97G 1 JYF' bUAMUubhu 7#&B&R			CAF5 B' < \$\$\$%
CAF5 ESTRUTURAL VESTIARIOS			BWG' B' < \$\$,
H-H IC ARMAÇÃO SAPATAS			F9J' B' < \$\$
6&' # ' 6&(
BSHS & #S' #&S&&	9G75@5 % &)	8909B-C 9G# : I BI : I BI \$S, I FSS	7CCF8' 9B: <

HEC 79FCGC 981757-QB5@ BEC 70X9F7-5@ 9GH: I BI: I BI \$S: I FSS' DHH & #S' #&S&& 9: +, ' \$