

Forma PILARES

P5=P20

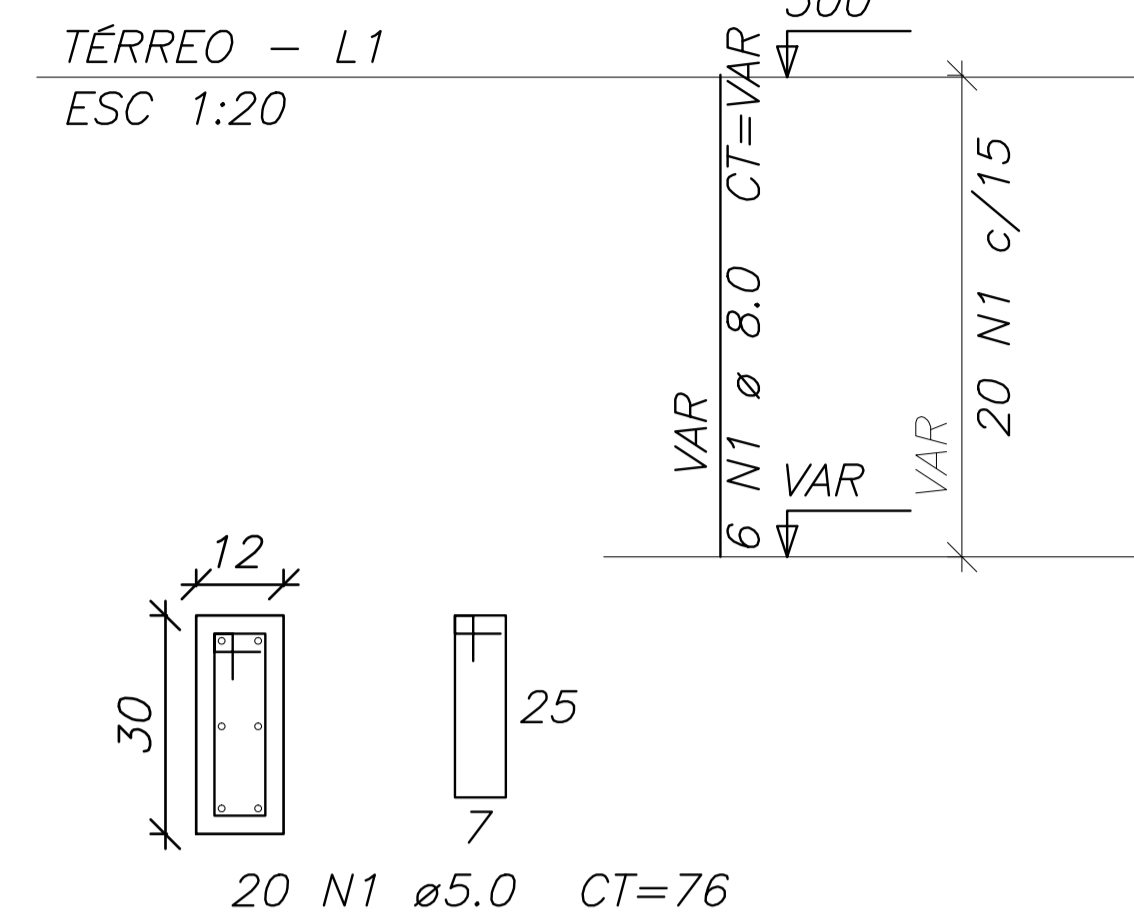

P1=P2=P3=P4=P6=P7=P11

P12=P13=P14=P17=P18=P19

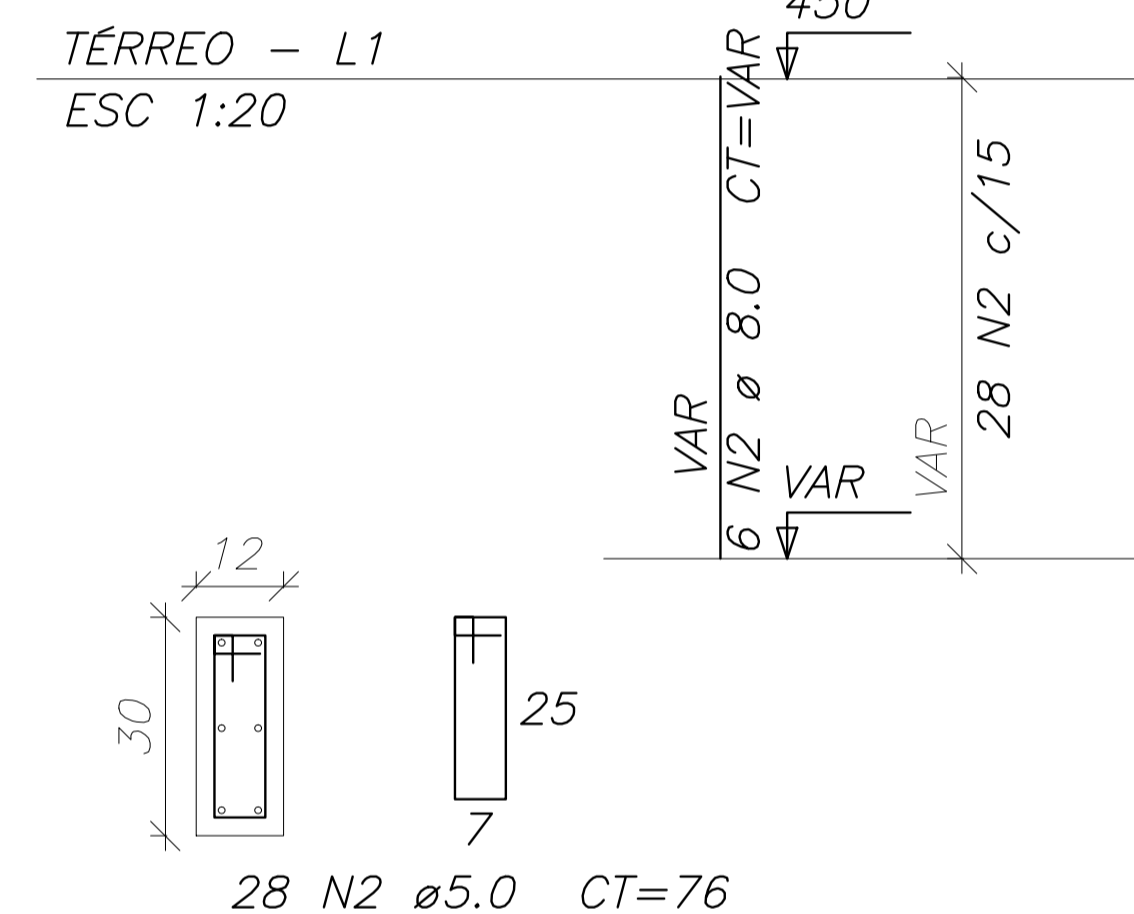

P15=P16=P21=P22

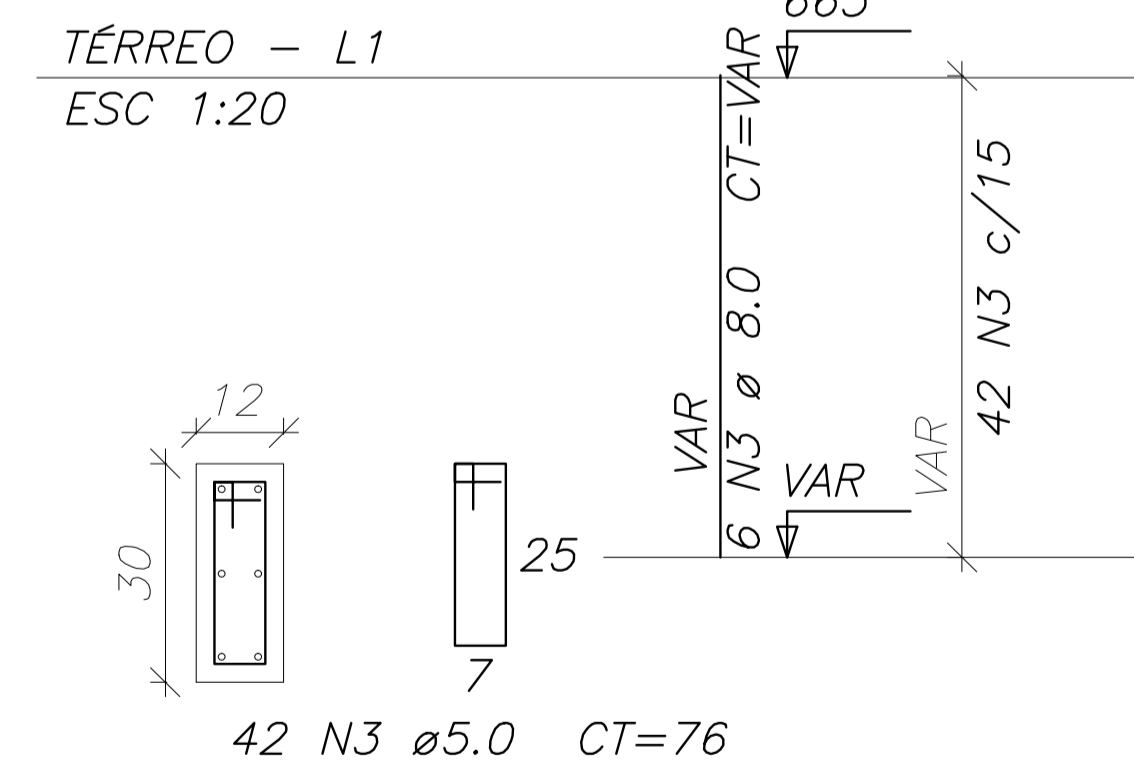

20 FORMA DOS PILARES
ESC. 1/50

Características dos Materiais

Fck (kgf/cm ²)	Ecs (kgf/cm ²)
200	212874

Detalhe 1 (esc. 1:20)

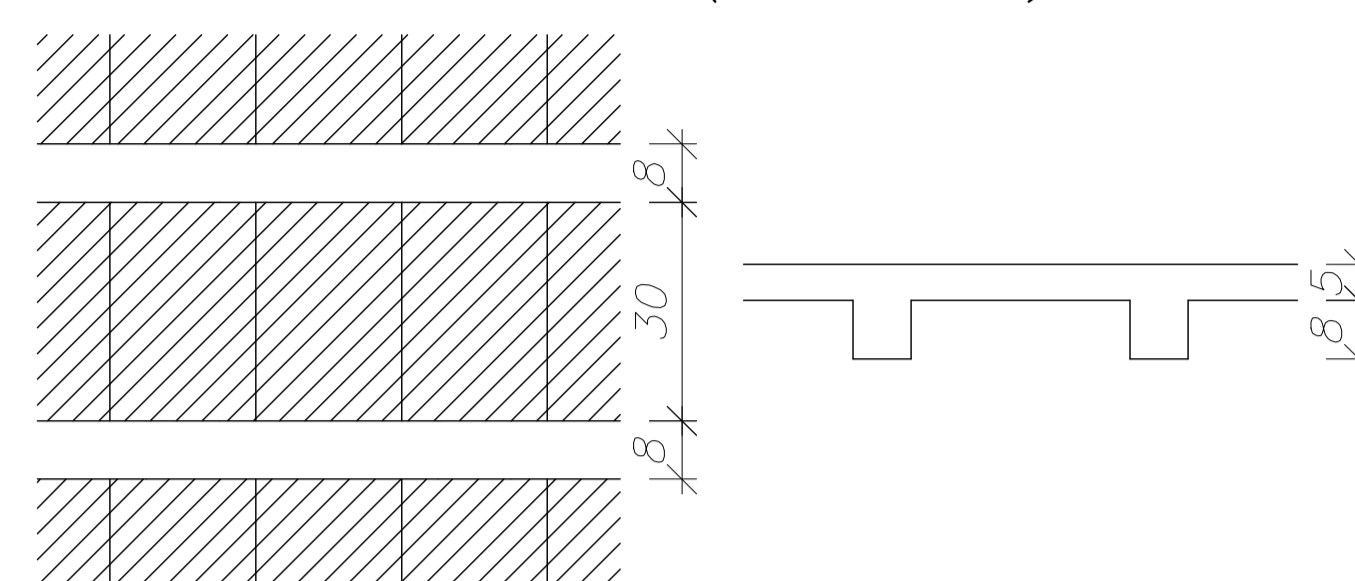

Forma SAPATAS

S1=S2=S3=S4=S5=S6=S7=S8=S9=S10

S11=S12=S13=S14=S15=S16=S17=S18=S19=S20

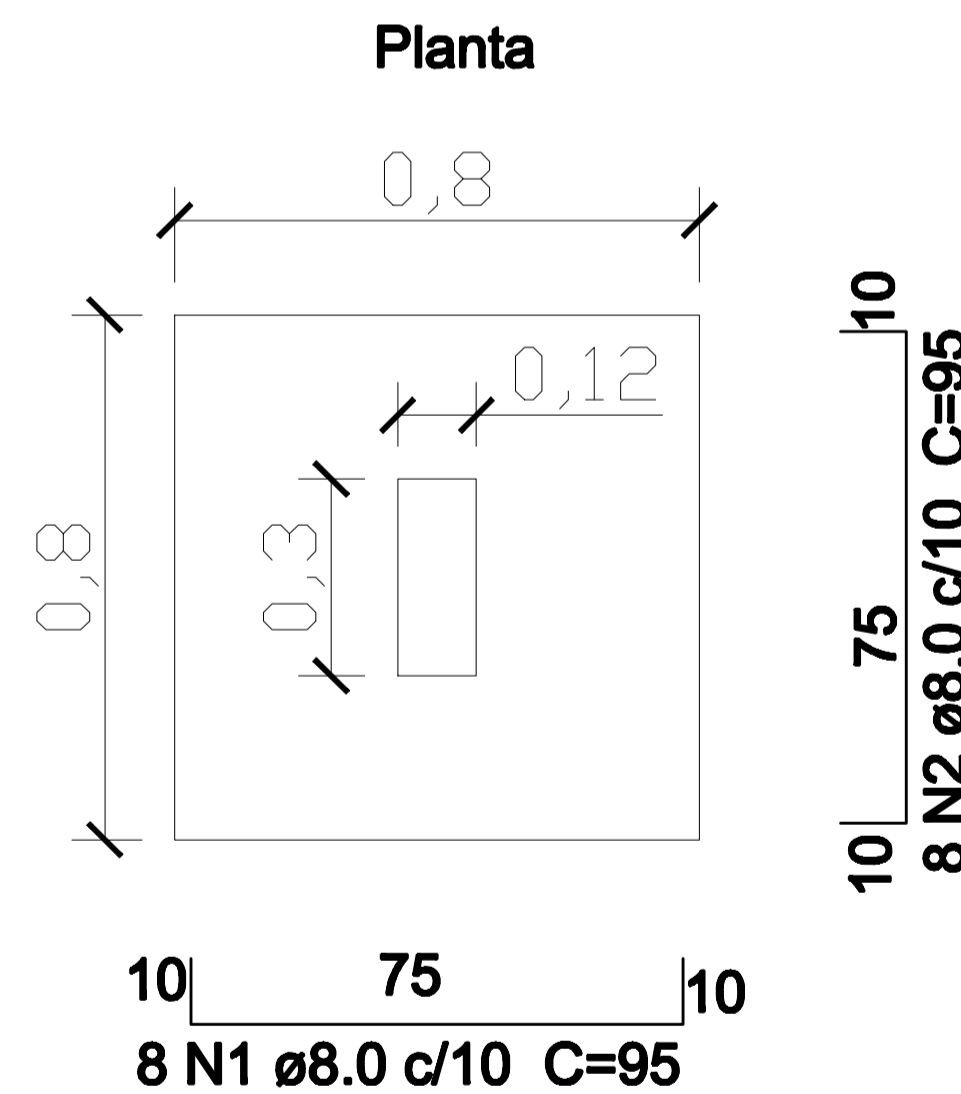

21 FORMA DAS SAPATAS
ESC. 1/50

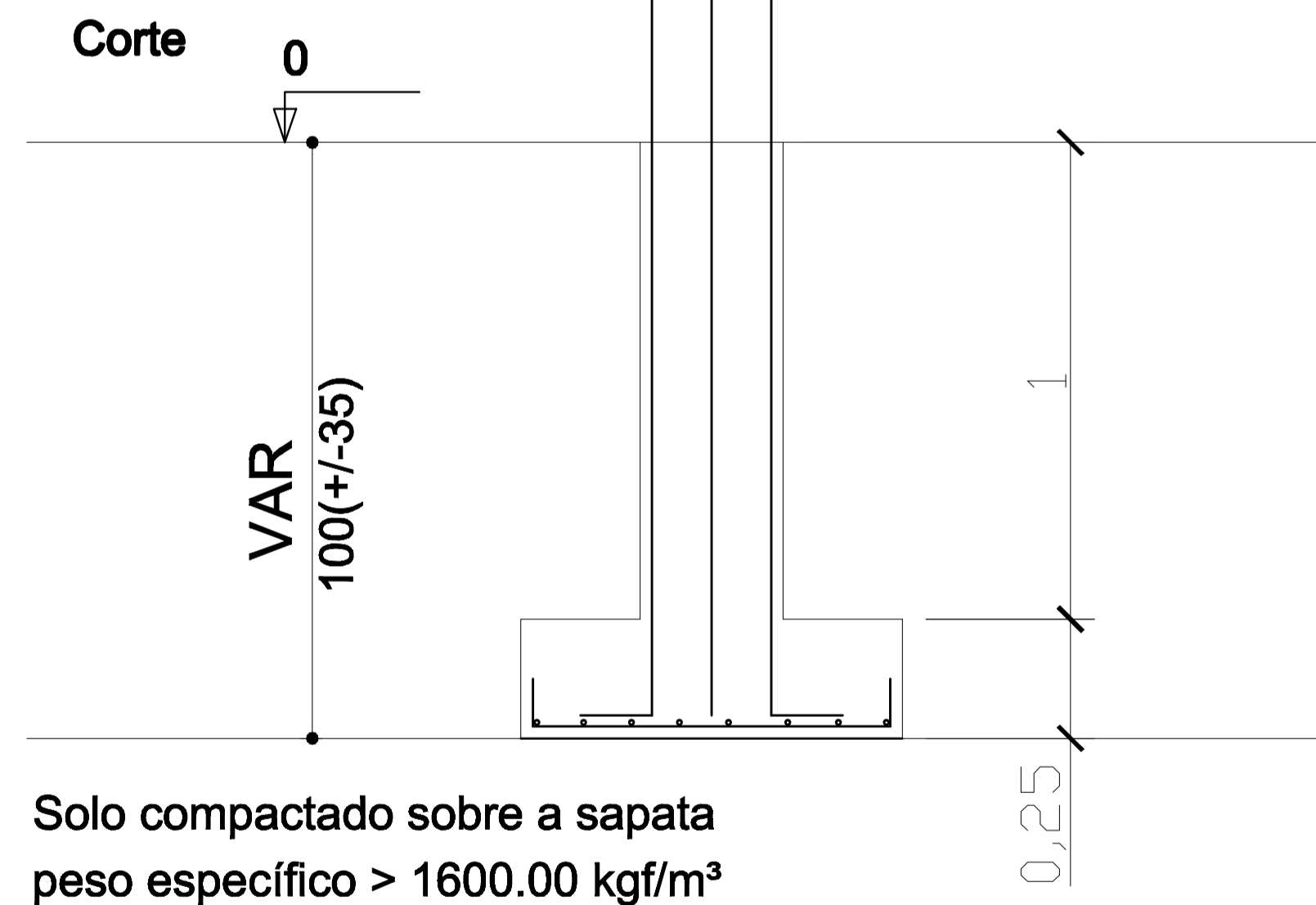

VIGAS TÉRREA

V=1/2/3/4/5/6/7/8/9/10/11
V=11/12/13/14/15/16/17/18

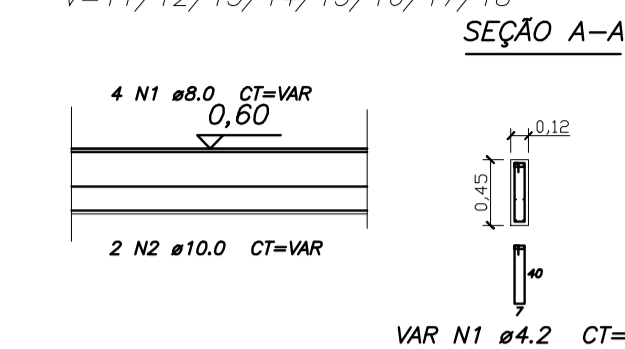

VIGAS AEREAS

V=1/3/4/7/10/11/12
V=13/14/15/17

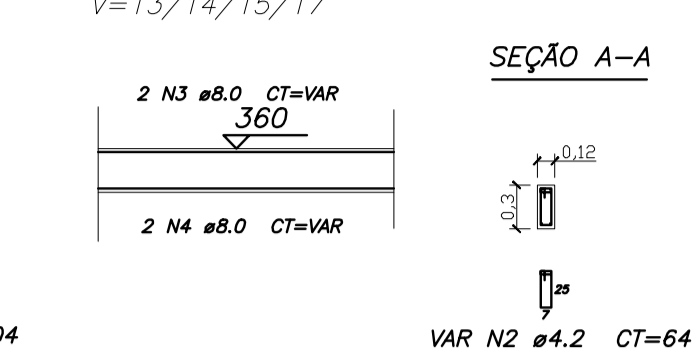

V=2/5/6/8/9/16/19

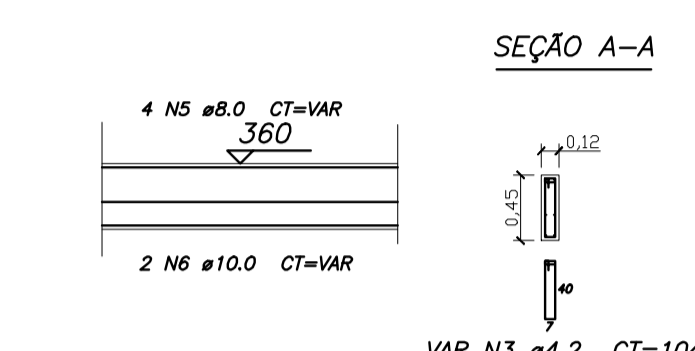

V=18

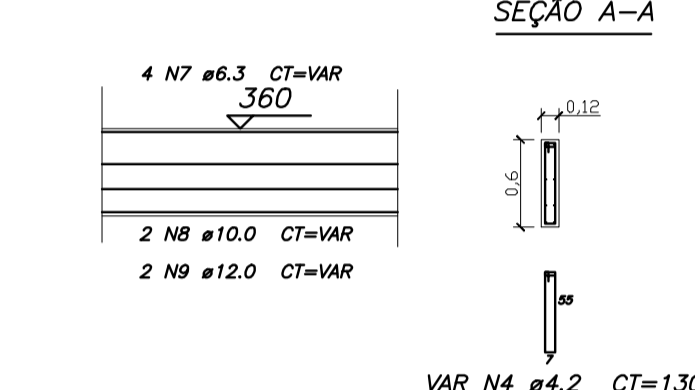

VIGAS CINTA DE AMARRAÇÃO

V=1/2/3/4/8/10/11

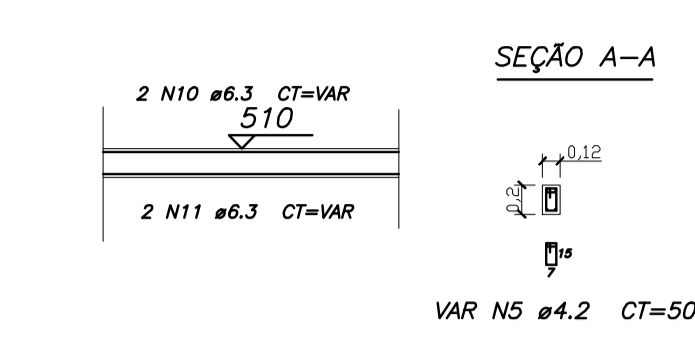

V=5/6/7/9

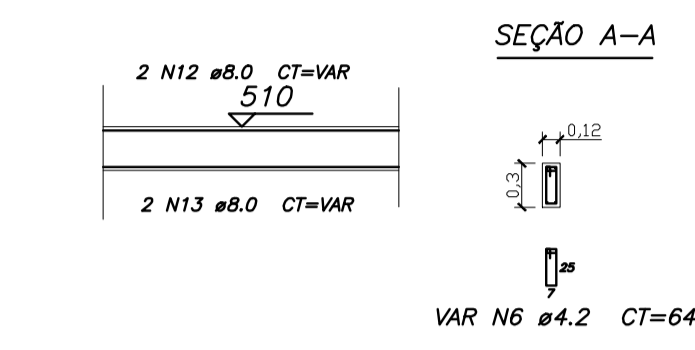

VIGAS teto caixa d'água

V=12/13/14/15

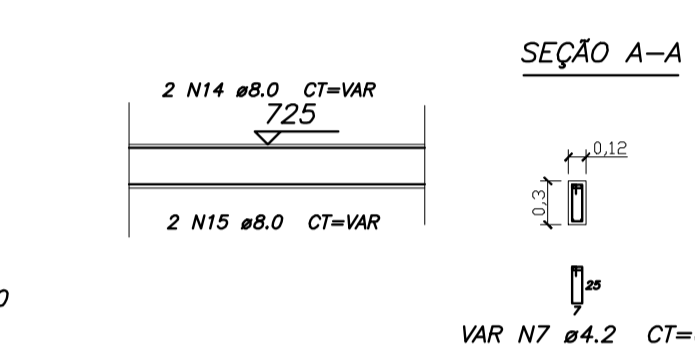

QUADRO DE ÁREAS EM m ²		
AMBIENTES	ÁREA	TOTAL
DORMITÓRIO	6,15 m ²	
COZINHA	7,98 m ²	
CIRCULAÇÃO	4,05 m ²	
WC.FEMININO	2,97 m ²	
WC.MASCULINO	2,97 m ²	
SALA 01	23,94 m ²	
SALA 02	23,94 m ²	
TOTAL ÁREA UTILI SEM VARANDA	72,00 m²	
VARANDA	29,00 m ²	
TOTAL ÁREA COM UTIL. VARANDA	101,00 m²	
TOTAL DA ÁREA CONSTRUIDA	108,65 m²	
TOTAL DA ÁREA DO TERRENO	435,00 m²	

APROVAÇÃO E DESCRIÇÃO:

PROJETO ARQUITETÔNICO EXECUTIVO

CAPELA MORTUÁRIA MUNICIPAL - BOM RETIRO

CLIENTE: PREFEITURA MUNICIPAL DE BOM RETIRO
ENDEREÇO: RUA: SANTA CATARINA
CENTRO - BOM RETIRO / SC

ARK sketch

FORMAS DOS PILARES, FORMAS DAS SAPATAS DETALHAMENTO DE VIGAS

ARQUITETO E URBANISTA: **RANDEL ROBSON BECKER** CAU N°: A 61214-6
ARQUITETA E URBANISTA: **MICHELLE ABDALA** CAU N°: A 56792-2
Rua: Pedro Hugo do Amaral Netto, nº 385
Bairro: Parque Residencial Capistrano - Bom Retiro - SC

DESENHO: **RANDEL ROBSON BECKER**

ESCALA: indicada

OBSERVAÇÕES:

PRANCHA **09**
09